



# MEYN WLD WHOLE LEG DEBONER M2.0

LIVE BIRD HANDLING | SLAUGHTERING | EVISCERATION | CHILLING | CUT UP | **DEBONING** | WEIGHING - GRADING - LOGISTICS

## Product highlights



Very high and consistent yield

Both left and right legs can be processed with the same system

Extremely low bone content

Relatively compact design

Stable and durable performance

Significant reduction of labor

Can process both Japanese and normal standard fillets...



## Meyn WLD whole leg deboner M2.0

**The Meyn WLD whole leg deboner M2.0 processes left and right anatomical legs with or without skin at a capacity of 3,600 legs per hour. The machine produces whole leg fillets with the high quality required by export markets. Besides a significant amount of labor reduction, an unrivaled high and consistent yield can be obtained without troublesome adjustments. All remaining manual activities are fast to learn, easy to execute and less stressful on the muscles and joints of the workers. This allows processors to obtain outstanding results in a short period of time and continuity is easily secured.**

The Meyn whole leg deboning solution comprises multiple integrated process steps that optimally prepare the supplied products prior to deboning. This not only allows for the production of whole leg fillets of an excellent quality and high yield, but also considerably reduces the necessary trim operations and thus labor requirements.



### Operation

The legs are supplied in crates, cartons or separated onto a conveyor belt directly from the cut up line. Subsequently, the legs are manually pre cut by two operators and transported to the loading operator. An automatic whole leg pre-cutter is available for the Physic HS cut up lines. Two loading operators take the legs and place them on the product carriers, which slowly pass by in front of him. Next, the product carrier take the legs through a sequence of automated deboning steps:

- Fixating the leg.
- Four (4) spring loaded knives cut tendons of the drum, while rotating the product.
- After cutting the tendons the drum meat is scraped downwards.
- The thigh meat is scraped in an upward motion.
- The knee joint is released from the leg fillet by a ringed shaped cutting blade.
- The processed whole leg fillet is automatically discharged.
- Finally, the leg bone is removed from the product carrier and the product carrier is ready for a new cycle.
- An inspection table, which is an option, completes the set up. Depending on end product requirements, 2 to 6 people are required.



m Product in and out

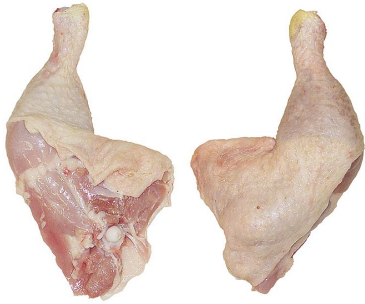

Skin on



Skinless

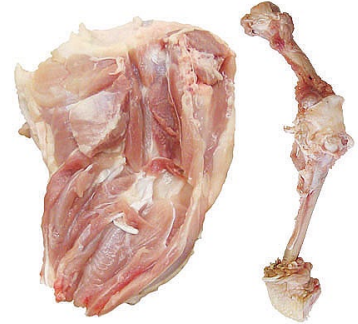

Whole leg fillet with or without skin

m Options

- Knife sharpener





# Meyn WLD whole leg deboner M2.0

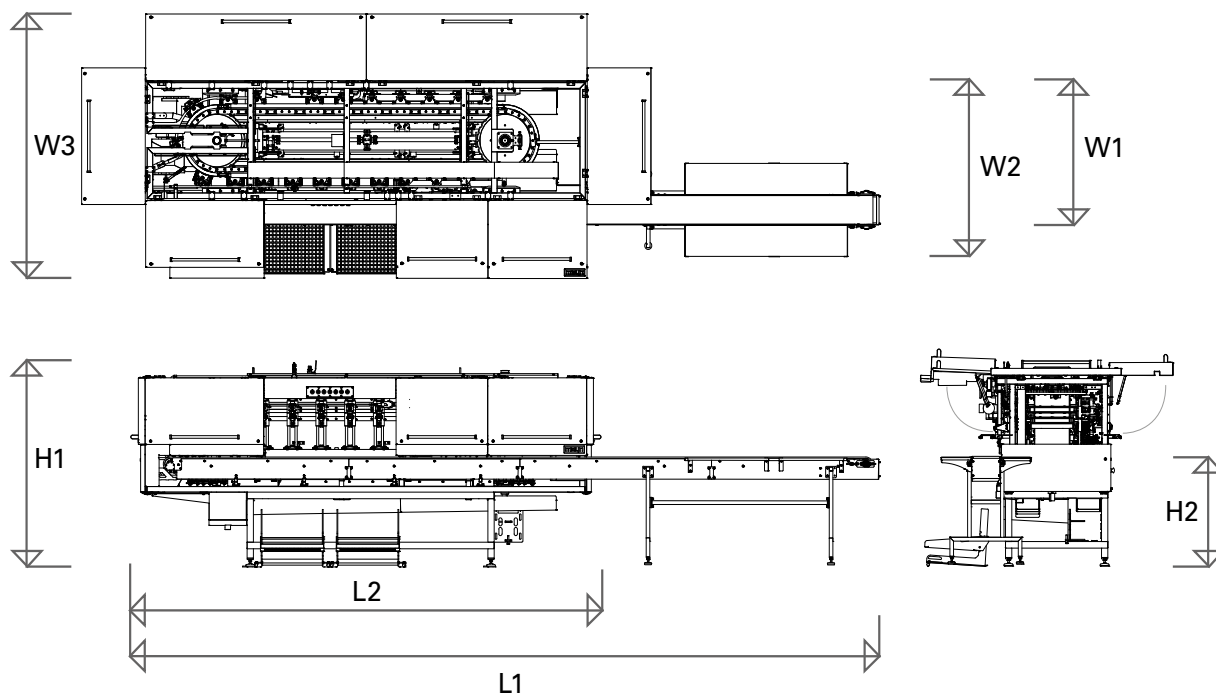

Capacity	LPH	3,600
Product weight anatomical leg skin on	g	200-600
Length (L1)	mm	8,300
Length (L2)	mm	5,100
Width (W1)	mm	1,570
Width (W2)	mm	2,000
Width (W3)	mm	2,800
Total height (H1)	mm	2,170
Working height (H2)	mm	1,160
Weight	kg	3.500
Electric power installed	kW	1x 1.1 + 1x 0.55 + 2x 0.18
Water connection	BSP	1/4"
Water consumption*	m <sup>3</sup> /hr	0-0.5
CIP system: Electric power installed	kW	2.2
Water consumption	m <sup>3</sup> /hr	0.8
Options: Pneumatic scissor: Air connection	BAR	6
Knife sharpener: Electric power installed	kW	0.37

\*only if water in deboning area is allowed

## HEAD OFFICE

Meyn Food Processing Technology B.V.  
 Westeinde 6, 1511 MA Oostzaan (Amsterdam)  
 P.O. Box 16, 1510 AA Oostzaan  
 The Netherlands

Phone: +31 (0)20 2045 000  
 Fax: +31 (0)20 2045 001  
 E-mail: sales@meyn.com  
 www.meyn.com



Poultry Processing Solutions